

PGT[®]120.COM

Personnel Grounding Tester

**Wrist Strap and Footwear Tester
with serial port**

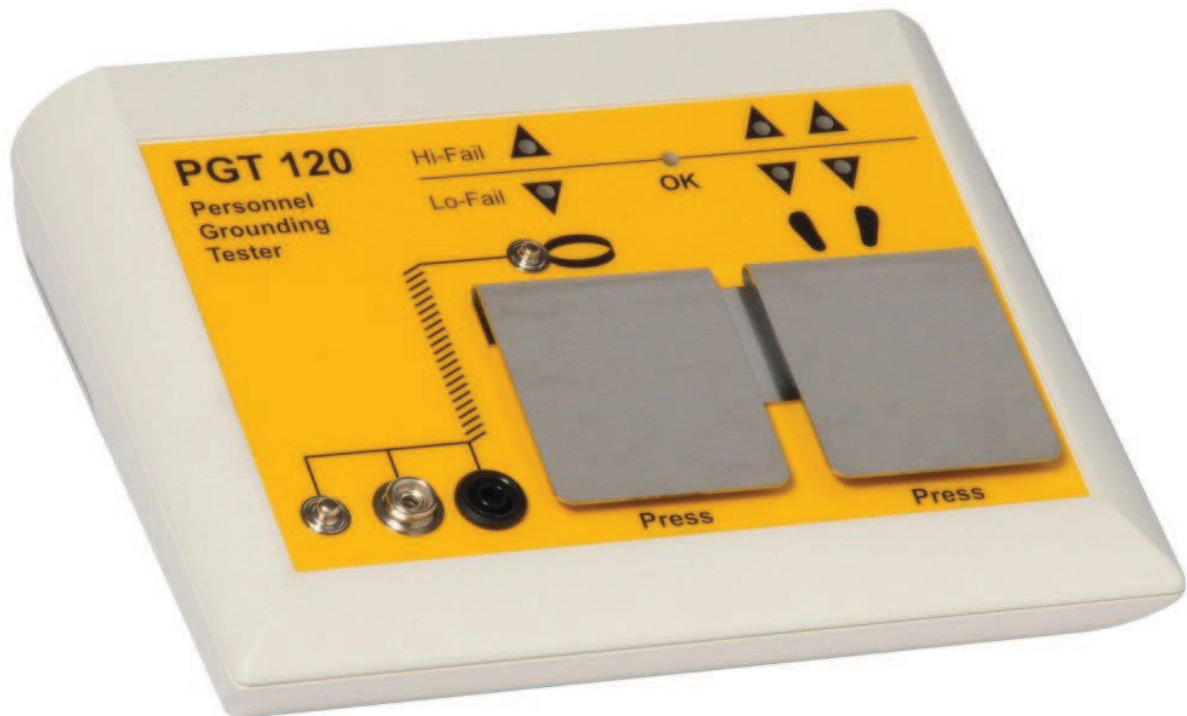

User's Manual

1 Table of contents

1	INHALTSVERZEICHNIS	2
2	ALLGEMEINES	4
2.1	Rücknahme und umweltverträgliche Entsorgung	4
3	INBETRIEBNAHME	5
4	BEDIENUNG	6
4.1	Gelenkbandprüfung einzeln.....	6
4.2	Spiralkabelprüfung einzeln.....	6
4.3	Schuhprüfung einzeln	7
4.4	Gelenkband- und Schuhprüfung gemeinsam	7
4.5	Schuhprüfung als Reihenschaltung.....	8
5	KONFIGURATION.....	9
6	DATENAUSGABE ÜBER RS232.....	10
7	ANSCHLÜSSE	12
8	MONTAGEANLEITUNG WANDKONSOLE.....	14
9	TECHNISCHE DATEN	15
10	ZEICHNUNGEN.....	16
1	TABLE OF CONTENTS	2
2	INTRODUCTION	4
2.1	Device return and environmentally compatible disposal.....	4
3	INSTALLATION.....	5
4	OPERATION	6
4.1	Wrist strap test.....	6
4.2	Coil cord test.....	6
4.3	Footwear test (single shoe)	7

- 4.4 Wrist strap and footwear test 7**
- 4.5 Footwear in series 8**

- 5 CONFIGURATION..... 9**

- 6 DATA OUTPUT VIA RS23210**

- 7 CONNECTORS12**

- 8 WALL MOUNTING INSTRUCTIONS14**

- 9 SPECIFICATIONS.....15**

- 10 PICTURES.....16**

2 Introduction

The Personnel Grounding Tester PGT[®]120.COM is an electronic test instrument for checking personnel grounding systems such as wrist straps, coil cords and footwear. The PGT[®]120 is suitable for compliance verification of the above products, according to the IEC 61340-5-1 Edition 1.0 (2007-08) or ANSI/ESD S 20.20 – 2007 (2007-03).

- The unit operates with 3 independent measuring circuits for the left shoe, the right shoe and the wrist strap. This makes it possible to measure all the values at the same time
- The unit has a serial port which is isolated from the measurement circuits.
- It is possible to enable or disable separately the measuring circuits.
- The order of tests is random.
- Footwear measurement can be configured to measure in series with hands free for passenger gates.
- Visual and audible test results, serial port and a dry relay contact for door opener
- Use the optionally available "Calibration Unit " Part No. **7100.PGT120.CU** to check the unit Hi and Lo limit values

2.1 Device return and environmentally compatible disposal

The **instrument** is a category 9 product (monitoring and control instrument) in accordance with ElektroG (German Electrical and Electronic Device Law). This device is not subject to the RoHS directive.

We identify our electrical and electronic devices (as of August 2005) in accordance with WEEE 2012/19/EU and ElektroG with the symbol shown to the right per DIN EN 50419.

These devices may not be disposed of with the trash.

Please contact our service department regarding the return of old devices.



3 Installation

The Unit is for desktop or wall mounting. The optionally available wall mounting frame (Part No. 7100.PGT120.WK) can be used to fix the unit to a wall.

The power is supplied by a power supply.

Use only an original power supply connected to the "AC12V" socket on the rear.. Do not connect any conducting articles with PGT[®]120.COM except original accessories (power supply, foot wear electrode and cabel for serial port) and the door opener.

Connect the foot electrode with the coloured marked plugs to the back of the unit for footwear test.

4 Operation

This tester has no power switch. Connecting the power supply activates the electrical circuit.

The measuring voltage is preset to 100V. Use the DIP switches 6+7 to adjust the voltage to either 30V or 50V.

4.1 Wrist strap test

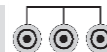

► Settings: **Only wrist strap** or **OR** is activated (DIP switch 1+2; RS232)

Put on the wrist strap and connect it via a coil cord to the snap or to the socket on the left side of the unit.

Press the left electrode and keep it pressed. A peep signal indicates the start of measurement. After a short measuring time the result is displayed.

OK	Green LED flashes	The measured value is o.k.
Hi-Fail	Red LED flashes, audible signal	Above the resistance upper limit
Lo-Fail	Red LED flashes, audible signal	Below the resistance lower limit <i>(not applicable if lower limit is disabled)</i>

Release the electrode.

4.2 Coil cord test



► Settings: **Only wrist strap** or **OR** is activated (DIP switch 1+2; RS232)

To check only the coil cord, connect the coil cord to the 3mm snap located inside the wrist strap symbol and to the 10mm snap or socket on the left side of the unit.

Press the left electrode and keep it pressed. A peep signal indicates the start of the measurement. After a short measuring time the result is displayed.

OK	Green LED flashes	The measured value is o.k.
Hi-Fail	Red LED flashes, audible signal	Above the resistance upper limit
Lo-Fail	Red LED flashes, audible signal	Below the resistance lower limit <i>(not applicable if lower limit is disabled)</i>

Release the electrode.

4.3 Footwear test (single shoe)



► Settings: **Only footwear** or **OR** is activated (DIP switch 1+2; RS232)

Stand on the foot electrode, then press the right electrode and keep it pressed. A peep signal indicates the start of measurement. After a short measuring time the result is displayed.

OK	Green LED flashes	The measured values of both shoes are o.k.
Hi-Fail right	Red LED flashes, audible signal	Right shoe above the resistance upper limit
Hi-Fail left	Red LED flashes, audible signal	Left shoe above the resistance upper limit
Lo-Fail right	Red LED flashes, audible signal	Right shoe below the resistance lower limit <i>(not applicable if lower limit is disabled)</i>
Lo-Fail left	Red LED flashes, audible signal	Left shoe below the resistance lower limit <i>(not applicable if lower limit is disabled)</i>

Release the electrode.

4.4 Wrist strap and footwear test

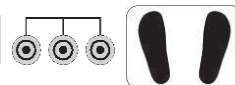

► Settings: **AND** function is activated (DIP switch 1+2; RS232)

Put on the wrist strap and connect it via a coil cord to the snap or socket on the left side of the unit.

Stand on the foot electrode, then press one electrode and keep it pressed. A peep signal indicates the start of measurement. After a short measuring time the result is displayed.

OK	Green LED flashes	All measured values are o.k.
Hi-Fail	Red LED flashes, audible signal	Above the resistance upper limit
Lo-Fail	Red LED flashes, audible signal	Below the resistance lower limit <i>(not applicable if lower limit is disabled)</i>

Release the electrode.

■ **The OK signal only appears when all measured values are within the limits.**

4.5 Footwear in series



► Settings: Footwear in series activated (DIP switch 8)

To show that "Footwear in series" is activated the red LED's for Hi-Fail of Footwear flash for a short time every 2s, while dissipative shoes are not detected.

The footwear test can be accomplished hands free, without touching a electrode. This is useful in combination with passenger handling gates. The resistance is measured between the two shoes. This mode cannot directly indicate the faulty shoe. Press the Shoe electrode on the instrument to identify it.

Stand with both feet onto the foot electrode. If the shoes are dissipative the measurement starts automatically. After a short measuring time the result is displayed and the connected gate will open.

OK	Green LED flashes	The measurement of the footwear in series is o.k.
Hi-Fail	Red LED flashes, audible signal	Above the resistance upper limit for series connection
Lo-Fail	Rote LED flashes, audible signal	Below the resistance lower limit <i>(not applicable if lower limit is disabled)</i>

You can step of the foot electrode.

Even if footwear in series is active, you can perform a test according chapter 4.1 to chapter 4.4 by pressing a electrode, for example to identify a bad shoe.

5 Configuration

The unit can be configured with the DIP switches on the rear according to the table below.

Standard settings are marked bold.

Switch 1	Switch 2	Test mode
OFF	OFF	"OR" (wrist strap or footwear test)
ON	OFF	Only footwear test
OFF	ON	Only wrist strap test
ON	ON	"AND" (wrist strap and footwear test)
Switch 3	Switch 4	Footwear upper limit
OFF	OFF	20 MΩ for single shoe / 40 MΩ for series
OFF	ON	35 MΩ for single shoe / 70 MΩ for series
ON	OFF	70 MΩ for single shoe / 140 MΩ for series
ON	ON	100 MΩ for single shoe / 200 MΩ for series
Switch 5		Lower limit
OFF		Lower limit disabled
ON		Lower limit enabled
Switch 6	Switch 7	Test voltage
OFF	OFF	30 V
OFF	ON	50 V
ON	--	100 V
Switch 8		Footwear test mode
OFF		test according to switch 1 + 2
ON		footwear in series active
Switch 9		Piep for footwear in series
OFF		At start of test
ON		At end of test if shoes OK
Switch 10		Door opener time
OFF		3s
ON		1s
Switch 11		Not used
OFF		-
ON		-
Switch 12		beeper
OFF		inactive
ON		active

6 Data output via RS232

Measured values and test result were output via serial port.

No.	Sense	Start	Prefix		Data	End	
1	value footwear in series	<STX>	RSG	<SP>	value in kOhm (UNR → under range) (OVR → over range)	<ETX>	<CR> <LF>
2	value wrist strap	<STX>	RHG	<SP>	value in kOhm (UNR → under range) (OVR → over range)	<ETX>	<CR> <LF>
3	value left shoe	<STX>	RSL	<SP>	value in kOhm (UNR → under range) (OVR → over range)	<ETX>	<CR> <LF>
4	value right shoe	<STX>	RSR	<SP>	value in kOhm (UNR → under range) (OVR → over range)	<ETX>	<CR> <LF>
5	test OK	<STX>	ERG	<SP>	OK	<ETX>	<CR> <LF>
6	Test failed	<STX>	ERG	<SP>	Error no.	<ETX>	<CR> <LF>

The order of data of one test is the same as above numbers, but not all data are output by one test.

<STX> = control character "Start of Text" (ASCII 002)
 <ETX> = control character "End of Text" (ASCII 003)
 <CR> = control character "Carriage Return" (ASCII 013)
 <LF> = control character "Line Feed" (ASCII 010)
 <SP> = Space (ASCII 032)

Error no.	Sense
1	Resistance wrist strap to low
2	Resistance wrist strap to high
4	Resistance left shoe to low
8	Resistance left shoe to high
16	Resistance right shoe to low
32	Resistance right shoe to high
64	Voltage to low or to high
128	tbd
-10	contact electrode was released to early

If several errors occur the error numbers are added.

Example 1:

Data : <STX>RHG 2671<ETX><CR><LF>
<STX>ERG OK<ETX><CR><LF>

Sense : Resistance wrist strap 2,671 MOhm,
Test result OK

Example 2:

Data : <STX>RSL OVR<ETX><CR><LF>
<STX>RSR 12415<ETX><CR><LF>
<STX>ERG 8<ETX><CR><LF>

Sense : Resistance left shoe exceeds the measurement range
Resistance right shoe is 12,415 MOhm
Test failed with error no. 8 (Resistance left shoe to high)

7 Connectors

The connectors for the power supply, the foot electrode, the door opener and the serial port are located on the rear side of the unit.

Use a "RJ12" western modular plug to connect the dry contact of the door opener. The door opener relay is triggered and stays for 1s or 3 seconds when the test result indicates OK.

Normally Open Pin 3,4
Normally Closed Pin 2,3

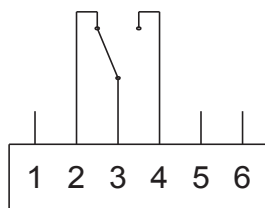

Contact function

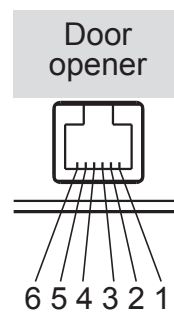

Connector View

The PGT[®]120.COM has a serial port RS232 to communicate with a PC or terminal.
The connector is located on the rear side of the unit.

Use a "RJ45" western modular plug to connect PGT[®]120.COM to PC or terminal.

Pin 4 = GND

Pin 5 = RxD

Pin 6 = TxD

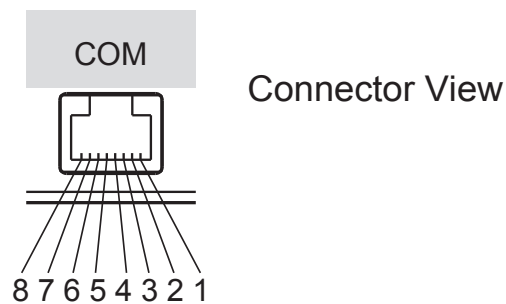

The names RxD and TxD are related to the function of PGT[®]120.COM

If you connect PGT[®]120.COM to a PC RxD and TxD have to be cross connected.

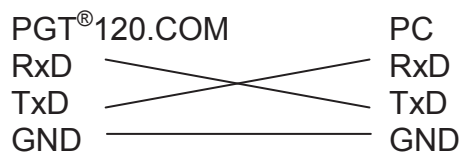

8 Wall mounting instructions

(Part No. 7100.PGT120.WK)

Fix the wall mounting plate with the supplied dowels and screws and stick the self-adhesive Velcro tapes according to the picture.

1. The surface of the plate and the bottom side of the PGT[®]120.COM have to be clean, dry and free of grease.
2. Remove protecting foil of the velcro tapes and do not touch the sticky side.
3. Apply the velcro tapes according to the picture onto the mounting plate.
4. Remove the second protecting foil of the velcro tapes and press the PGT[®]120.COM against them.
5. After 24 Hour curing time the PGT[®]120.COM can be removed from the wall mounting plate

Before removing the unit, please unplug all wires.

Hold the unit on both sides and pull it forwards. To fix it again, press it back onto the velcro tapes.

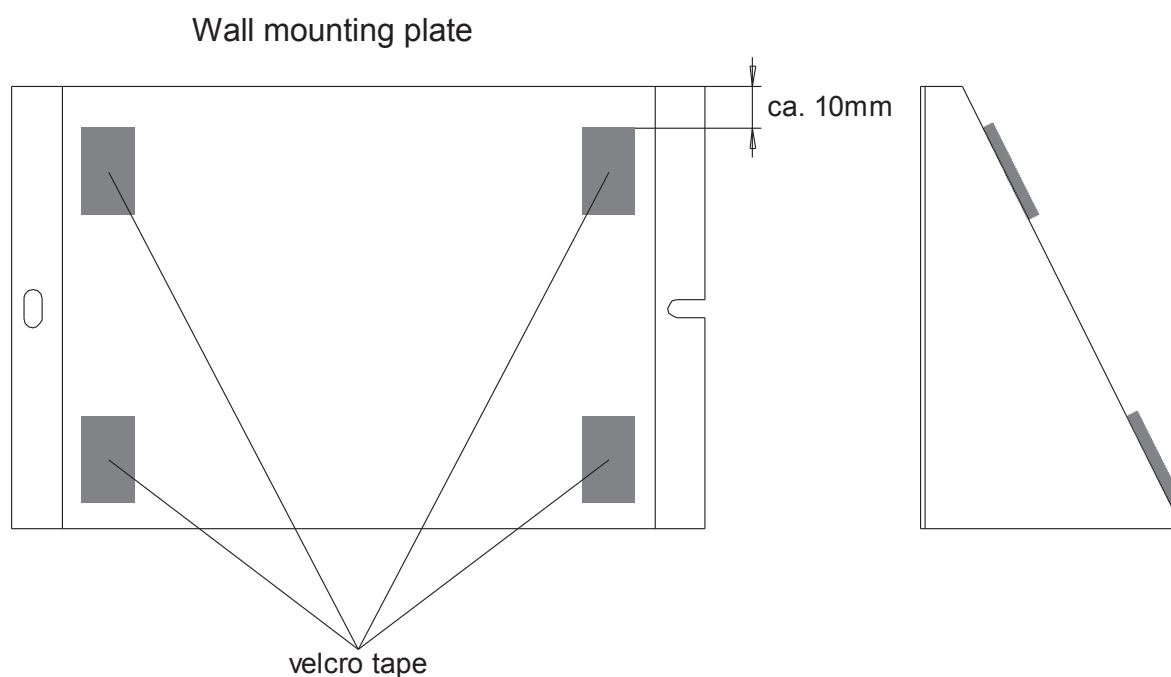

9 Specifications

<u>Operating voltage:</u>	external power supply 230V / 50Hz	
<u>Operating conditions:</u>	15 ... 40°C	up to 75% relative humidity, non condensing
<u>Storage conditions:</u>	-10 ... 60°C	up to 85% relative humidity, non condensing
<u>Connectors:</u>	Wrist strap	10mm snap, 4mm snap, 4mm socket
	Foot electrode	2 sockets 4mm
	Door opener	Western socket 6 pin RJ-12
	Serial port	Western socket 8 pin RJ-45
	external 12VAC power supply (Use only for the original power supply supplied with the instrument)	
<u>Serial port:</u>	RS232	9600 baud 8 Data bit no Parity 1 Stop bit
<u>Measuring ranges:</u>	Wrist strap	750kΩ ... 35MΩ
	Footwear - each shoe	100kΩ ... 100MΩ
	Footwear in series	200kΩ ... 200MΩ (Hands-free-Mode)
	Tolerance	± 10%
<u>Display ranges:</u>	Wrist strap	650kΩ ... 200MΩ
	Footwear each shoe / in series	80kΩ ... 200MΩ
<u>Test voltage:</u>	open circuit voltage	30V ± 10% 50V ± 10% 100V ± 10%
<u>Signals:</u>	Green LED	"OK"
	Rote LED's and buzzer	"Hi-Fail" or "Lo-Fail"
	Door opener	Dry contact "OK"
<u>Contact ratings:</u>	max. voltage	60V
	max. current	2A
	max. power	50 VA
<u>Operating modes:</u>	Single test "OR" ,	Double test "AND"
	Only wrist strap test ,	Only footwear test
	Hands-free-Mode	
<u>Weight:</u>	app. 500g	
<u>Dimensions:</u>	150 x 200 x 63 mm	
<u>Serial number:</u>	On the side of the unit	
	Complies with CE	

10 Pictures

footwear test

LED
"upper limit exceeded"

LED
"below low limit"

LED
"measured value in the limit"

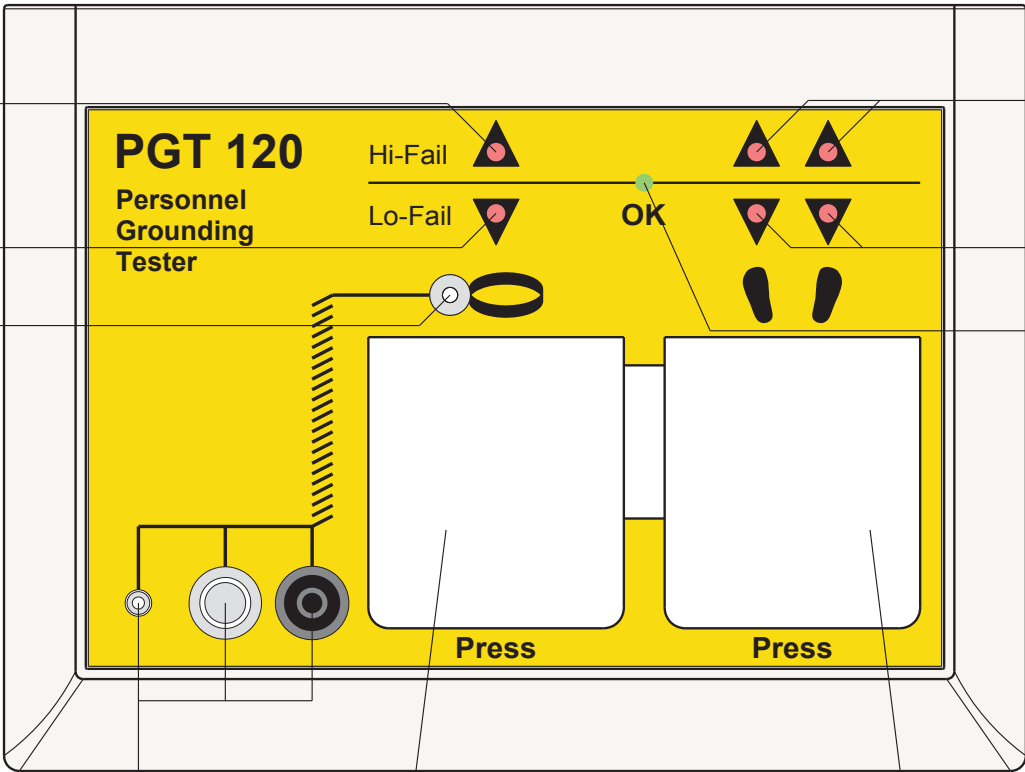

wrist strap test

LED
"upper limit exceeded"

LED
"below low limit"

male snap 3mm

connections for wrist strap test

electrode for wrist strap test

electrode for footwear test

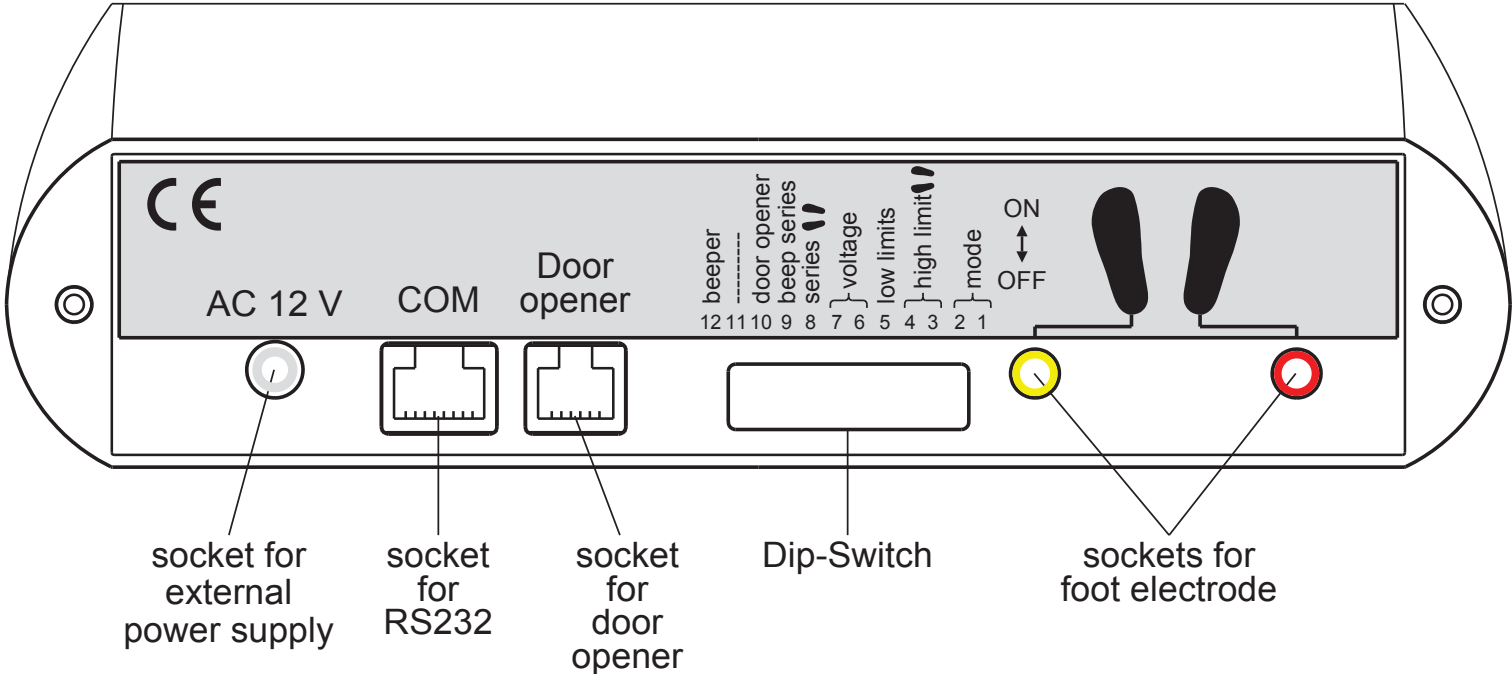

Änderungen vorbehalten

Subject to change without notice

WOLFGANG WARMBIER GmbH & Co. KG

Untere Gießwiesen21

D-78247 Hilzingen

Telefon +49 77 31 86 88-0

Telefax +49 77 31 86 88-30

e-mail: info@warmbier.com

<http://warmbier.com>

